



INFORMATION FOR MEDIA PLANNERS

SCOPE

The Journal of Clinical Psychiatry (JCP) publishes original peer-reviewed material by recognized authors in the psychiatric and behavioral/neural sciences, with special emphasis on subjects relevant to the practicing clinical psychiatrist. In addition to original research, JCP publishes review articles; special focus sections on women's issues, dementia, child and adolescent psychiatry, and the research and perspectives of early career psychiatrists; case reports; clinical reports; book reviews; and letters to the editor. JCP also publishes highlights of academic symposia and timely clinician commentary augmenting original research and offers Continuing Medical Education.

Additionally, JCP publishes special Supplements during the year that generally contain proceedings from scientific symposia.

IMPACT FACTOR (IF) and READERSHIP

IF ▶ JCP is the third most cited psychiatric journal in the world with an IF of 5.533 (December 2008, Journal Citation Reports).

Readership ▶ JCP ranks highest in total number of office- and hospital-based average issue readers of psychiatric journals (June 2009, Focus® Readership Study). More psychiatrists report receiving JCP than any other psychiatry journal, and it is the best-read scientific journal in the field.

INDEXING

JCP is indexed in MEDLINE, Excerpta Medica, Psychological Abstracts, Current Contents, Science Citation Index, Hospital Literature Index, Biological Abstracts, Cumulative Index to Nursing and Allied Health Literature, International Nursing, Industrial Medicine, Chemical Abstracts, and Adolescent Mental Health Abstracts.

ASSOCIATION

JCP is the official journal of the American Society of Clinical Psychopharmacology. The ASCP, founded in 1992, is a group of nearly 800 physicians who study and practice psychopharmacology and advocate for psychopharmacology and clinical research, consisting of doctoral-level investigators of clinical psychopharmacology or pharmacology.

CIRCULATION

Qualified recipients include psychiatrists in direct patient care (office, hospital, and military settings), residents, US and non-US paid subscribers, and others allied to the field of psychiatry.

	Recipients	Qualified	Non-Qualified
Total	35,588	35,113*	475

BREAKDOWN BY SPECIALTY

Psychiatrists	28,514
Geriatric psychiatrists	648
Child and adolescent psychiatrists	2,838
Other (includes paid)	3,113

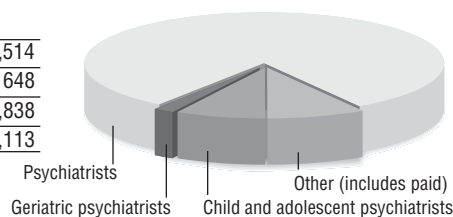

BREAKDOWN BY GEOGRAPHY

US and US Territories	34,222
International	891

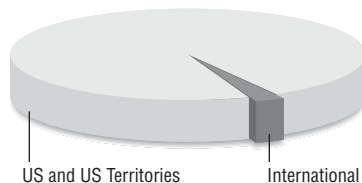

* Source: BPA Circulation Statement June 2009. Circulation verification by BPA Worldwide. For semiannual circulation update, go to www.bpaww.com.



RATE CARD CONTENTS

Page 1	Information for MEDIA PLANNERS	<ul style="list-style-type: none"> • Circulation • Subscription Rates • Contacts
Page 2	INSERT Information for MATERIALS SUPPLIERS	<ul style="list-style-type: none"> • Inserts • Mechanical Requirements • Shipping Information
Page 3	RUN-OF-BOOK Information for MATERIALS SUPPLIERS	<ul style="list-style-type: none"> • Run-of-Book Ads • Mechanical Requirements • Electronic File Information • Shipping Information
Page 4	Information for MEDIA PLANNERS	<ul style="list-style-type: none"> • General Information • Advertising Rates • Due Dates

SUBSCRIPTIONS

SUBSCRIPTION RATES (US \$)

Subscription Rates Based on a 12-Month Period

Individual Subscriptions

US	Print + Online	\$156
	Online Only	\$86
International	Print + Online	\$207
	Online Only	\$86

REPRINTS

Advertisers may purchase reprints only from the publisher. Contact Maureen Bunner-Hunsucker at mhunsucker@psychiatrist.com.

CONTACTS

STAFF Editor in Chief	Alan J. Gelenberg, MD <i>President and CEO</i> <i>Healthcare Technology Systems</i> <i>Madison, Wisconsin</i>
Publisher	John S. Shelton, PhD

ADVERTISING CONTACT AND ALL ORIGINAL INSERTION ORDERS	Bob Massa <i>Integrity Media Partners, LLC</i> 230 Kings Highway East, Suite 318 Haddonfield, NJ 08033 E-mail: bob@imp-online.com Phone: 856-432-1555 Fax: 856-494-1488
--	--

CONTACTS FOR AD SPECS AND PUBLISHING EXTENSION DATES

Primary Contact	David Twombly E-mail: dtwombly@psychiatrist.com Phone: 901-273-2754
Secondary Contact	Lori McStay E-mail: lmestay@psychiatrist.com Phone: 901-273-2757

INSERT REQUIREMENTS

2 PAGE, SINGLE LEAF

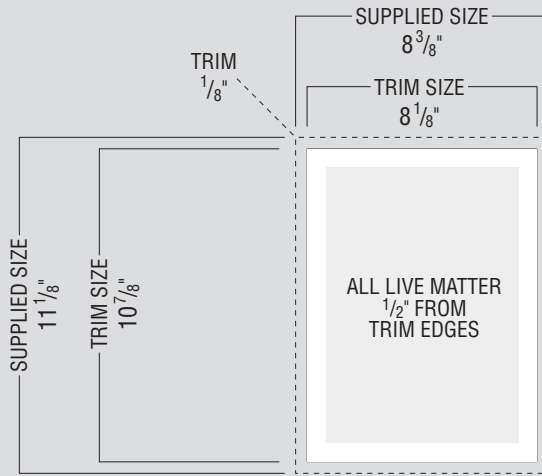

4 OR MORE PAGES

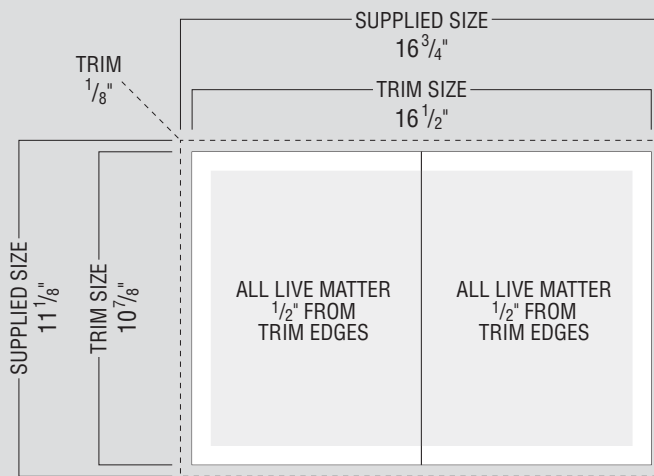

OTHER SPECIFICATIONS

Quantity Required

- 40,000 (includes overage)

Paper Stock

- **Heaviest** ▶ 80-lb text
- **Lightest** ▶ 60-lb text

Finishing

- Inserts should be supplied folded and/or tipped
- Journal jogs to head

Non-Standard Inserts

The following types of inserts must be approved by the publisher:

- Gatefold
- Z-fold
- Flap Inserts
- Any inserts with a unique design

Questions

- **Primary Contact**
David Twombly
e-mail: dtwombly@psychiatrist.com
Phone: 901-273-2754
- **Secondary Contact**
Lori McStay
e-mail: lmcstay@psychiatrist.com
Phone: 901-273-2752

DUE DATES

Year	Issue Month	Materials to Printer
2009	December	11-25-09
2010	January	12-22-09
	February	1-22-10
	March	2-22-10
	April	3-22-10
	May	4-21-10
	June	5-21-10
	July	6-22-10
	August	7-22-10
	September	8-20-10
	October	9-22-10
	November	10-22-10
	December	11-22-10
2011	January	12-22-10

CONTACT & SHIPPING INFORMATION

EXTENSIONS ▶ Primary Contact:
David Twombly
e-mail: dtwombly@psychiatrist.com
Phone: 901-273-2754
Fax: 901-273-2752

Secondary Contact:
Lori McStay
e-mail: lmcstay@psychiatrist.com
Phone: 901-273-2757
Fax: 901-273-2752

SHIP INSERTS TO ▶ **Dartmouth Printing Company**
Attn: Lisa Davis
69 Lyme Rd
Hanover, NH 03755
Phone: 603-643-2220

Label Skids ▶ Each box must be marked with the following information:

- Journal name: *Journal of Clinical Psychiatry*
- Month of insertion
- Product name

Note ▶ The printer will reject inserts shipped COD.

RUN-OF-BOOK REQUIREMENTS

FULL PAGE

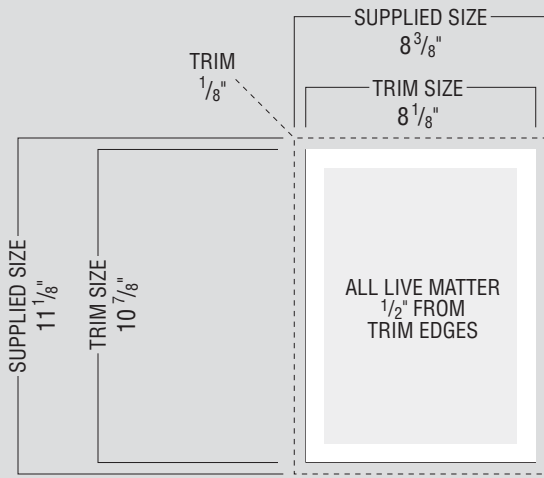

SPREAD

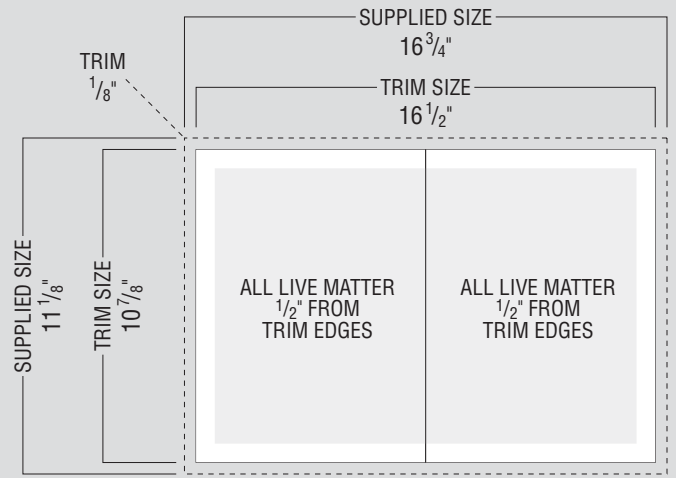

HALF PAGE VERTICAL

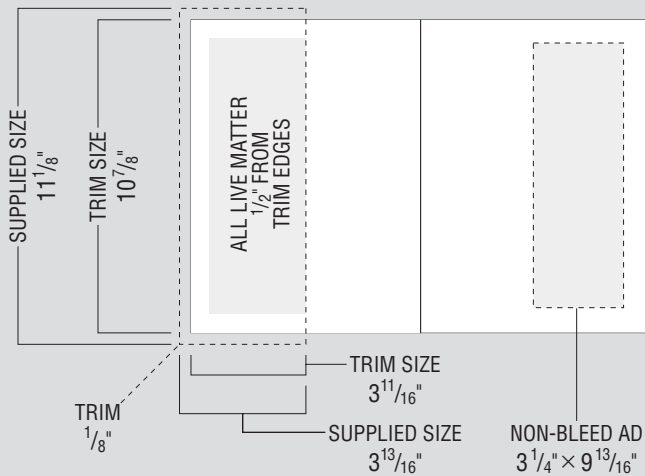

HALF PAGE HORIZONTAL

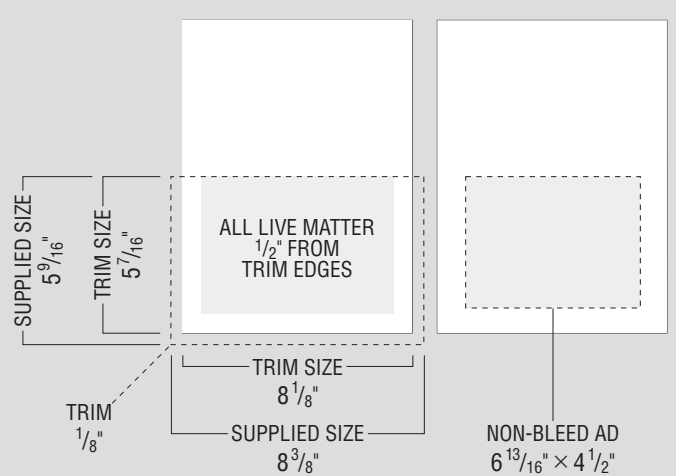

ELECTRONIC FILE INFORMATION

- ELECTRONIC FILES ▶**
- Format specifications ▶** All disk or e-mailed ads should be submitted as PDFs, fonts embedded.
 - Maximum density ▶** 350%
 - Rotation of colors ▶** KCMY
 - Note ▶** The materials supplier is responsible for having all links up-to-date in the electronic files prior to burning the CD or sending by e-mail.
- ACCEPTABLE MEDIA ▶** Disk or e-mail, with a pressmatch provided for color ads.

CONTACT & SHIPPING INFORMATION

Disk ▶ **David Twombly**
Physicians Postgraduate Press, Inc.
850 Ridge Lake Blvd, Suite 300
Memphis, TN 38120
e-mail: dtwombly@psychiatrist.com
Phone: 901-273-2754
Fax: 901-273-2752

E-mail ▶ **David Twombly**
dtwombly@psychiatrist.com

If you do not receive a confirmation for e-mailed material, call **Lori McStay** at **901-273-2757**.

DUE DATES

Year	Issue Month	Materials to Publisher
2009	December	11-11-09
2010	January	12-11-09
	February	1-10-10
	March	2-12-10
	April	3-12-10
	May	4-12-10
	June	5-12-10
	July	6-11-10
	August	7-12-10
	September	8-12-10
	October	9-10-10
	November	10-12-10
	December	11-12-10
2011	January	12-10-10

GENERAL

PLACEMENT

- **Advertising Placement** Interspersed with editorial material.
- **Editorial/Advertising Ratio** Average is about 60%/40%.

GUIDELINES

- **Advertising Copy** Acceptance is subject to approval by publisher, especially for advertorials.
- **Commission** 15% on all advertising. Any pass-through charges are noncommissionable.

INSERTS

REQUIREMENTS

- **Quantity:** 40,000 (includes overage)
- **Paper stock:** Heaviest: 80-lb text; Lightest: 60-lb text
- Inserts of 4 pages or more should be supplied folded and/or tipped.
- Journal jogs to head.

AD RATES

Earned Frequency	1 page
1x	\$5,975
6x	4,429
12x	4,147
24x	4,058
36x	3,947
48x	3,835
60x	3,787
72x	3,738
84x	3,628
96x	3,516
108x	3,411
120x	3,305
132x	3,199
144x	3,095
156x	2,989

DUE DATES

Year	Month	Commitment	Materials to Printer
2009	December	11-5-09	11-25-09
2010	January	12-4-09	12-22-09
	February	1-5-10	1-22-10
	March	2-5-10	2-22-10
	April	3-5-10	3-22-10
	May	4-5-10	4-21-10
	June	5-5-10	5-21-10
	July	6-4-10	6-22-10
	August	7-5-10	7-22-10
	September	8-5-10	8-20-10
	October	9-3-10	9-22-10
	November	10-5-10	10-22-10
	December	11-5-10	11-22-10
2011	January	12-6-10	12-22-10

SCHEDULING

Contact dtwombly@psychiatrist.com for extensions.

- When new copy is not provided by the materials due date, the ad appearing in the most recent preceding issue will be repeated.
- Cancellation must be made by the first of the month prior to the month of publication.
- Unless requested to be held, material will be disposed of 1 year after its last use.

RATES

Cost Per Thousand

- **Full page black-and-white, 24 times:** \$112.72

Frequency

- Calculated on the number of ad pages, eg, a 2-page ad that runs in 3 issues achieves the 6x frequency rate.
- The earned rate is based on the total number of advertising pages published in JCP within the January through December 12-month period.
- Advertising purchased by a parent company and subsidiaries is combined for determining the earned rate.

NEGOTIATED POSITIONS

Contact dtwombly@psychiatrist.com for information/rates in regard to any negotiated positions, which include:

- Cover tips
- Business reply cards
- Polybag advertising

Other Costs (noncommissionable)

If an ad needs special consideration for processing, a noncommissionable pass-through charge may be incurred. The agency will be notified separately at the time the charge is incurred, before the cost is invoiced.

RUN-OF-BOOK

PREMIUM POSITIONS (COMMISSIONABLE)*

5 Up-front & cover positions

Rate: 25% over the earned single-page black-and-white rate

- Cover 2
- Between Masthead and Table of Contents
- Between Table of Contents and CME Pretest
- Adjacent to first Editorial (immediately after CME Pretest)
- Cover 4 (no premium for Cover 3)

1 Back-of-book position

Rate: 15% over the earned single-page black-and-white rate

- Adjacent to CME posttest

COLOR RATES (COMMISSIONABLE):

Four colors: \$1,345 per page

Standard color: \$502 C, M, or Y

Matched colors: For cost of matched colors, contact David Twombly at dtwombly@psychiatrist.com or 901-273-2754.

AD RATES

Earned Frequency	1/2 page	1 page
1x	\$3,540	\$5,975
6x	3,015	4,429
12x	2,783	4,147
24x	2,660	4,058
36x	2,617	3,947
48x	2,561	3,835
60x	2,540	3,787
72x	2,516	3,738
84x	2,466	3,628
96x	2,416	3,516
108x	2,378	3,411
120x	2,314	3,305
132x	2,240	3,199
144x	2,165	3,095
156x	2,092	2,989

DUE DATES

Year	Month	Commitment	Materials to Publisher
2009	December	11-5-09	11-11-09
2010	January	12-4-09	12-11-09
	February	1-5-10	1-10-10
	March	2-5-10	2-12-10
	April	3-5-10	3-12-10
	May	4-5-10	4-12-10
	June	5-5-10	5-12-10
	July	6-4-10	6-11-10
	August	7-5-10	7-12-10
	September	8-5-10	8-12-10
	October	9-3-10	9-10-10
	November	10-5-10	10-12-10
	December	11-5-10	11-12-10
2011	January	12-6-10	12-10-10

*See NEGOTIATED POSITIONS (above right) for other advertising opportunities.